

# TIN KNOCKER

## TK 1016 LEAF BRAKE

### INSTRUCTIONS & PARTS DIAGRAM



### **TAAG MACHINERY CO.**

(Master Distributor)

1257-B Activity Dr.

Vista, CA 92081

Tel: (800) 640-0746 Fax: (760) 727-9948

Website: [www.tinknocker.com](http://www.tinknocker.com) \* Email: [taag@sbcglobal.net](mailto:taag@sbcglobal.net)

**TIN KNOCKER  
SAFETY RULES  
TK 1016 LEAF BRAKE**

1. Never use a machine or tool for anything other than its intended purpose. Use the proper tool and equipment for the task.
  
2. Do not operate the machine in excess of its rated capacity.

**WARRANTY**

All new TAAG Machinery Co. machines are sold with a one-year limited warranty, on factory defective parts. The warranty is limited to the original user. TAAG Machinery Co. at its option, will repair, replace or refund the purchase price of any part, tool or machine that fails during the warranty period. TAAG Machinery Co. will pay normal shipping charges for replacement parts. After 90 days from date of purchase, all express or overnight delivery charges are the responsibility of the customer. Purchaser must deliver to TAAG Machinery Co., at the address below, any written claim, with proof of original purchase. Replacement parts will be invoiced to purchaser and credit issued when the failed part is delivered to TAAG Machinery Co.. Removal, reinstallation or replacement parts shall be at purchasers' / user's expense. Failure due to improper use of the machine voids the warranty.

**NOTE:** This machine has been tested and adjusted prior to shipment, but can and often does require readjustment due to vibration and bouncing during transport. Readjustment can easily be done by following the procedures described within. These are procedures with which you, as a user, should be familiar, as you will use them repeatedly over the life use of the machine. If you have difficulty in performing these procedures, we are here to support you. Call us at: (800) 640-0746

**TAAG MACHINERY CO.**

(Master Distributor)

1257-B Activity Dr.

Vista, CA 92081

Tel: (800) 640-0746 Fax: (760) 727-9948

**Website:** [www.tinknocker.com](http://www.tinknocker.com) \* **Email:** [taag@sbcglobal.net](mailto:taag@sbcglobal.net)

## TK 1016 Leaf Brake,

**RECEIVING THE MACHINE** Inspect before signing Bill of Lading.

Upon receipt closely examine the Leaf Brake for damage during shipment. Any loss or damage should be noted in detail on the delivery receipt and reported to your distributor immediately. Free replacement from TK International is dependant upon the notation and the Bill of Lading on delivery slip.

## **INSTALLING THE MACHINE**

Locate the Leaf Brake in a well-lighted area on a solid, level floor. The Leaf Brake must be securely bolted to the floor. Be sure you have adequate room to swing both handles and Bending Leaf.

## **PRECAUTIONS**

DO NOT use the Leaf Brake to bend rods, nails or wires. This will cause damage to the edge of the top blade. DO NOT exceed the capacity of the Leaf Brake.

## **OPERATING THE MACHINE**

**BENDING EDGE ALIGNMENT:** When Bending Leaf is in down position, edge of Leaf should be flush with edge of Bottom Bar (122).

To maintain this alignment, ensure brake sets level on floor:

1. Adjust Bending Leaf center with Truss Nut (75).
2. Adjust Bottom Center with Truss Nut (121).
3. Adjust Bending Leaf Ends with Hinge Adjustment Screws (95). Loosen Hinge Bolts (93) before and tighten again after adjustment.

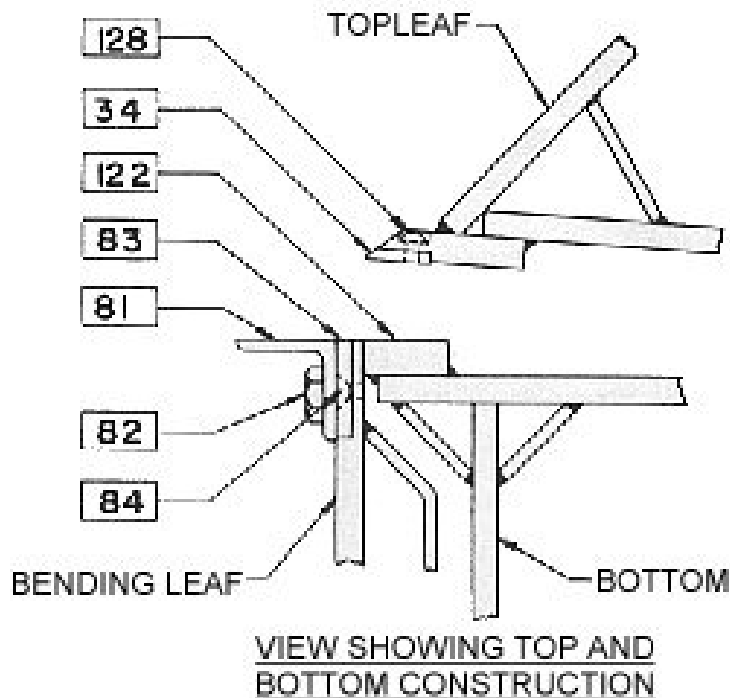

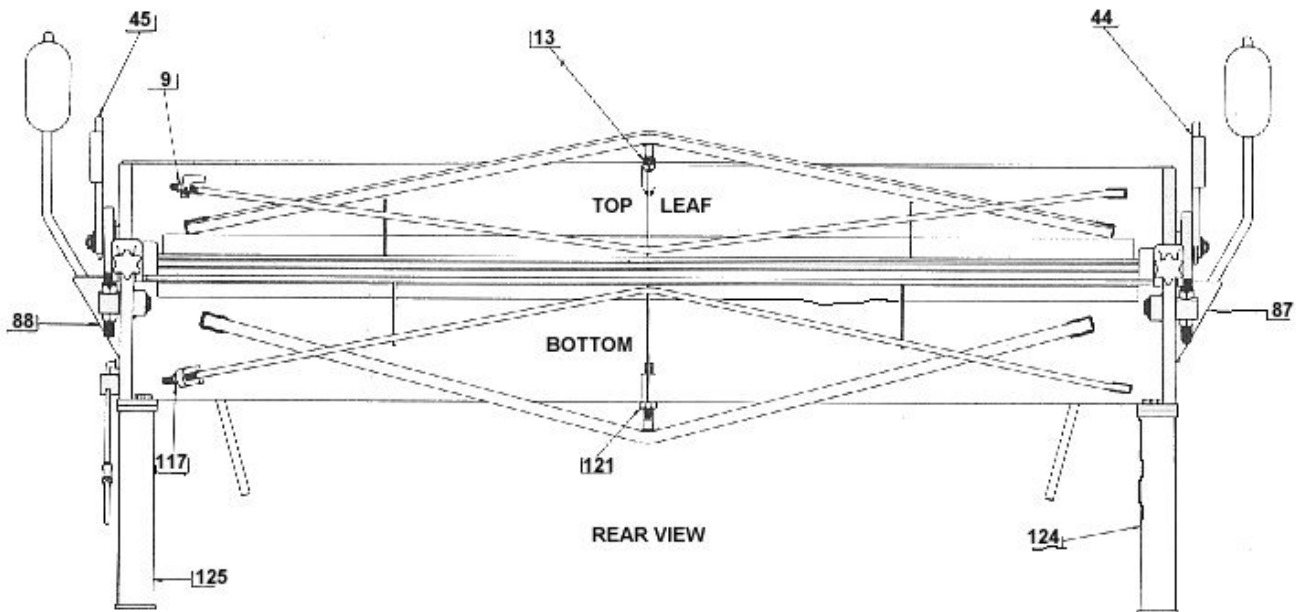
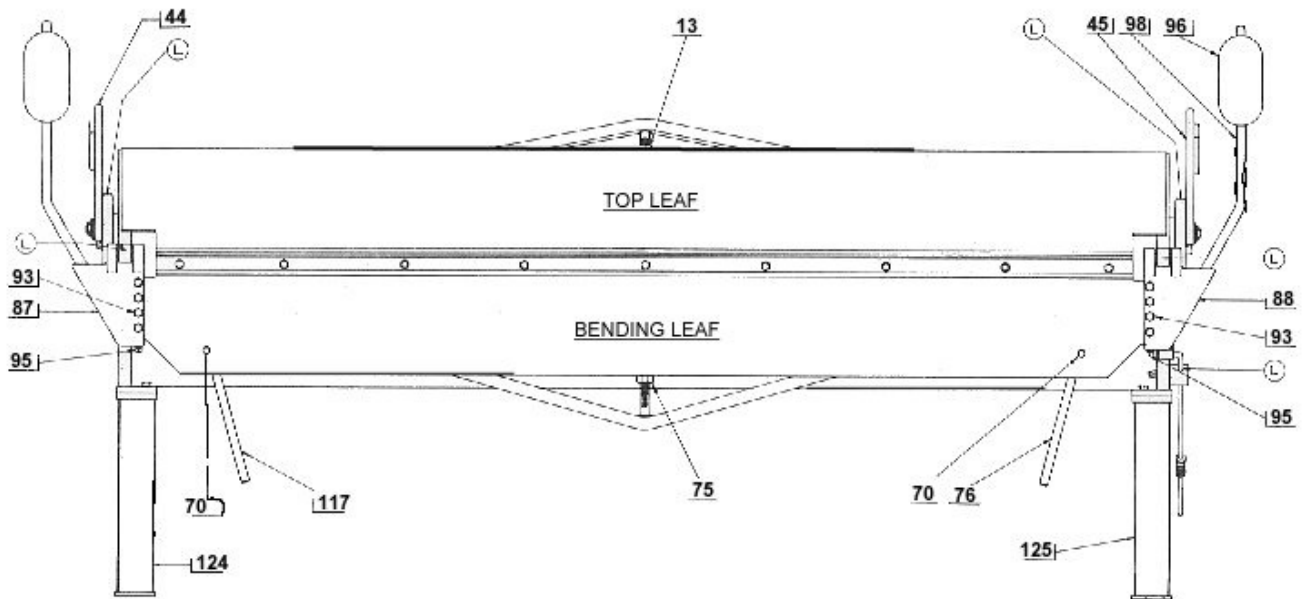

### **BOWED BENDING LEAF ADJUSTMENT**

If bending Leaf becomes bowed in center after use, tighten both Tension Bolts (70) until center is brought into a straight line.

## **LUBRICATION**

Lubricate occasionally with SAE-30 oil where indicated by symbol **L** except for Top Adjustment Screws (22) and Nuts (31) which are lubricated by filling Saddle (28/29) cavities with grease.

## **ADJUSTING FOR METAL THICKNESS**

Clearance for bends is obtained by moving Top Leaf back at bending edge. If material to be bent is within four gauges of capacity, move Top Leaf back twice the thickness of the material. With lighter material, move Top Leaf proportionately forward if sharper bends are desired:

1. Unclamp Handles (44/45) slightly.
2. Adjust Top Leaf with Top Adjustment Handles (23).

Clamping pressure of the Links (56/57) is changed by adjusting the Nuts (60).

## **DUPLICATE BENDS**

Adjustable Stop Gauge (100) may be positioned at any point on Rod (104) by means of Lock Bolt (102) to limit the degree of bend.

## **COUNTERBALANCE**

Counterweight (96) can be raised or lowered on Rod (98) to properly counterbalance the Bending Leaf.

## **OVER BENDING ADJUSTMENT**

If sheet bends over further on one side than on the other, set the Top Leaf back on the end where sheet is over bending.

1. Unclamp Handles (44/45) slightly on side that is over bending.
2. Adjust Top Leaf with Top Adjustment Handle (23).
3. Reclamp Handle (44/45).

## **CREEPING TOP LEAF ADJUSTMENTS**

Should Top Leaf creep forward when clamping material:

1. Check that brake sets level on floor.
2. Ensure that top Adjustment Screw Collars (25) are locked into position so that the Screws (22) cannot move back and forth in Saddles (28/29) – front shoulder of Screws and face of Collars must be snug against Saddles with minimum clearance.
3. If still creeping, wedge under rear of Leg (124/125) at end that creeps until stopped. Replace wedge with permanent block of correct height.

## **CAPACITY**

The bending capacity of the brake is determined by the bending edge thickness provided by the Bending Leaf Bars (81/83) when mounted on Leaf.

1. Insert Bar (83) with Angle Bar (81) allows the full rated 1” minimum flange on capacity material.
2. Insert Bar alone without Angle Bar reduces capacity of brake four gauges.
3. Removing both Insert Bar and Angle Bar reduces capacity of brake seven gauges.

These bars are removed only to make narrow offset bends.

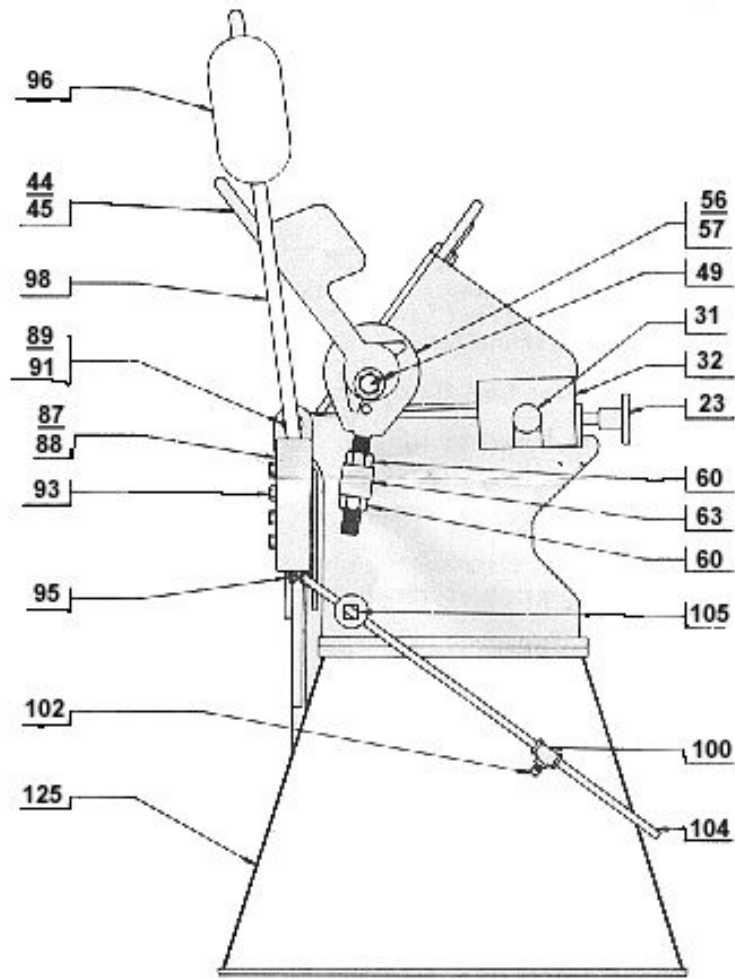

RIGHT HAND END VIEW

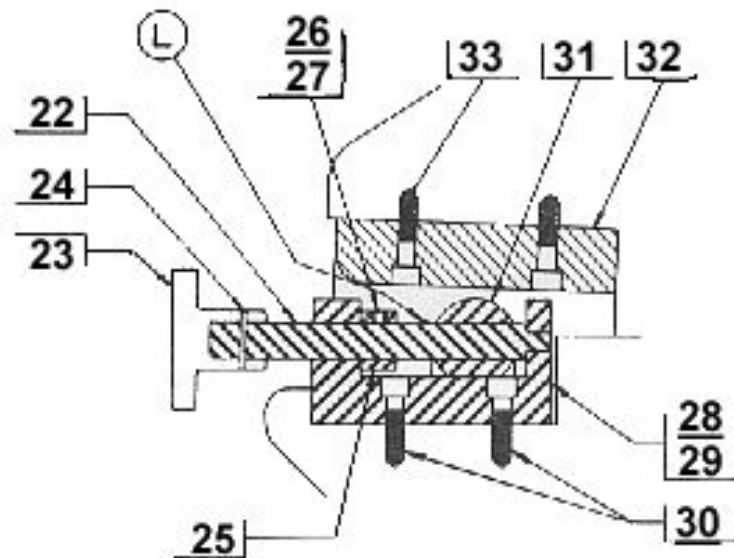

**CROSS SECTION THRU  
ADJUSTING MECHANISM**

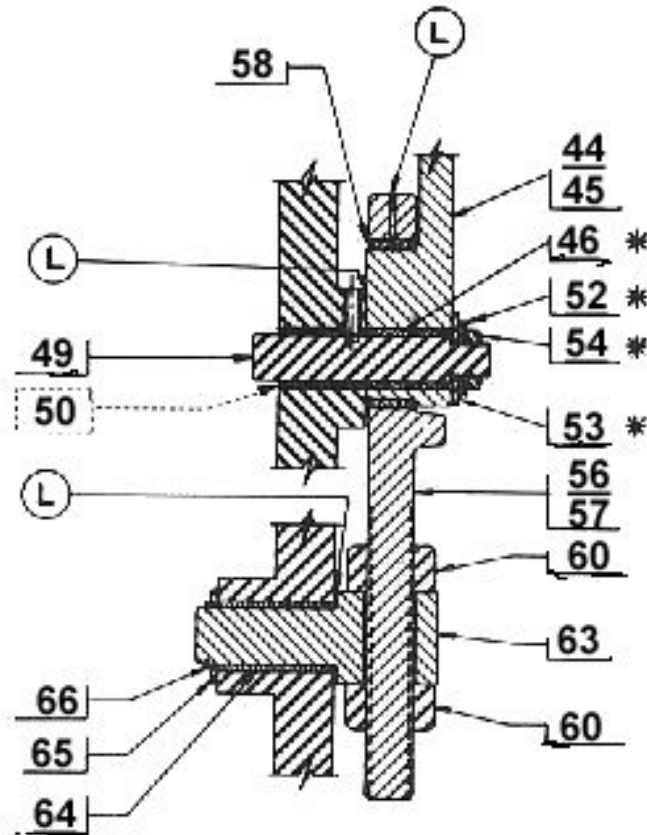

**CROSS SECTION THRU LINK  
AND LINK PIVOT BLOCK**

### CAUTIONS

Bend short pieces of material in center of brake to equalize the strain. Never bend against seams unless Links (56/57) are adjusted to clamp the full multiple thickness of seam; and, Top Leaf is set back for clearance of the same full multiple thickness.

Always have both angle Bar (81) and Insert Bar (83) mounted to leaf when making capacity bends. When forming sections of wide girth such as cornices, to equalize the buckles in the sheet:

1. Start bend near the center of sheet, or,
2. Make a kink in the opposite end of sheet from the bend first made.

Sheets are not always perfectly flat and a buckle left in one end while the other is straightened by clamping in the brake, will throw the first bend out of line when it, in turn, is straightened.

Always use material with square-sheared edges –rolled-edges will cause material to bow. Never use Brake to bend rods – these will nick Nose Bar.

Always adjust for differences in gauges – especially never force-clip the Top on material heavier than that for which the Links and Top are set by using pipe extensions on Clamp Handles for leverage.

Parts For 1016 Leaf Brakes			No. REQ'D.
Fine No.	Part No.	Description	
22	1016001	Top Adj. Screw	
23/24	1016002	Top Adj. Handle/Pin.	
25/26/27	1016003	Top Adj. Collar/Lock Screw Rod	
28/29/30	1016004	Top Adj. Saddle L/R	
31	1016005	Top Adj. Nut	
32/33	1016006	Top Adj. Slide/Bolts	
34	1016007	Nose Bar-sharp	
44/45	1016008	Clamp Handle L Clamp Handle R	
46	1016009	Clamp Handle Brg.	
49	1016010	Clamp Shaft	
50	1016011	Clamp Shaft Brg.	
52	1016012	Clamp Shaft Spring	
53	1016013	Clamp Shaft Washer	
54	1016014	Clamp Shaft Nut	
56/57	1016015	Link L/R	
58	1016016	Link Brg.	
60	1016017	Link Adj. Nuts	
63	1016018	Pivot Shaft	
64	1016019	Pivot Shaft Brg.	
65	1016020	Pivot Shaft Washer	
66	1016021	Pivot Shaft Lock	
81/82	1016022	Angle Bar/Bolt	
83/84	1016023	Insert Bar/Screw	
85/86	1016024	Former/Clamp	
87/88	1016025	Hinge L Hinge R	
89	1016026	Hinge Pin	
91	1016027	Hinge Pin Brg.	
93	1016028	Hinge Bolt	
95	1016029	Hinge Adj. Screw	
96	1016030	Counterweight	
98	1016031	Counterweight Rod	
100/102	1016032	Stop Gauge/Lock Bolt	
104	1016033	Gauge Rod	
105	1016034	Gauge Guide	
122	1016035	Bottom Bar	
124/125	1016036	Leg L/R	
128	1016037	Nose Bar Screws	